

Instruction Manual

HOT AIR FRYER

Item No.: SC70

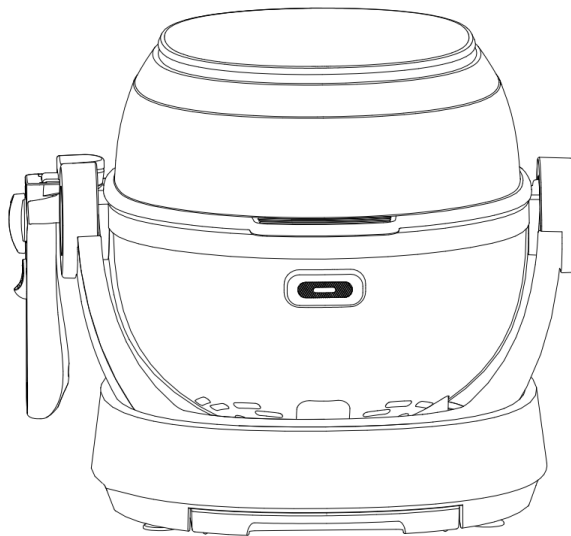

Important safeguard

Read all instructions before using

When using an electrical appliance, basic safety precautions should always be followed, including the following:

1. Read all instructions before using appliance.
2. Do not touch hot surface
3. Before use, check your local voltage corresponds with the specifications showing on the appliance name plate located under the appliance.
4. To protect against electric shock, do not immerse cord, or this appliance in water or other liquid.
5. Close supervision is necessary when any appliance is used by children or near children.
6. When not in use, always keep the unit is "OFF" and unplug from the mains power supply
7. The unit should be operated on separate electrical circuit from other operating appliance. If the electric circuit is overloaded with other appliances, this appliance may not work properly.
8. Must use extreme caution when moving a cooking pot containing hot food.
9. Do not let the cord hang over the edge of the table, counter, or touch any hot surface.
10. Place the appliance securely in the center of the counter or work space.
11. Do not touch hot surface. Use handles to lift or move.
12. Do not allow children to use this appliance.
13. Close adult supervision must be provided when this appliance is used near children.
14. The use of accessory attachments not recommended by the appliance manufacturer may cause injuries.
15. Do not operate on a non-heat resistant glass, wood cooking surface, or a table cloth. It is imperative

that a heat resistant cooking surface with heat finish be placed beneath this unit.

16. Do not operate this or any appliance with a damaged cord or plug or after the appliance malfunctions, or has been damaged in any way.

17. When not in use, and before cleaning, unplug the appliance from the mains power supply. Before putting on or taking off parts, allow the unit to cool first.

18. Do not use outdoors.

19. Do not place near hot gas or electric burner, or in a heated oven.

20. To reduce the risk of potential shock, if the plug does not fit, contact a qualified electrician for assistance. Do not attempt to defeat or modify the plug in any way.

21. Do not clean the unit with metal scouring pads. Pieces can break off the pad and short-circuit electrical parts, creating a possibility of an electrical shock and damaging the unit.

22. To protect against electrical shock, do not immerse plug, power cable or the base of the air-fryer in water or any other liquid.

23. ATTENTION: To protect against electric shock, cook only in the pot included.

24. The air-fryer is for indoor, household use only.

25. Do not use the appliance for anything other than its intended purpose.

26. Save these instructions.

Overview

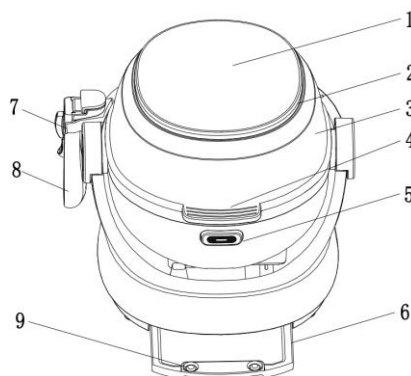

1. Control panel
2. Heat Emission Hole
3. Transparent Cover
4. Lid Handle
5. Lid release button
6. Oil receiver
7. Handle Holder
8. Handle
9. Oil plug

Handle Holder

1. The handle holder needs to be installed by yourself, as shown in the picture below: Align the buckles of the handle holder with the elongated square holes of the base bracket, then press down firmly to fasten the handle bracket onto the base bracket.

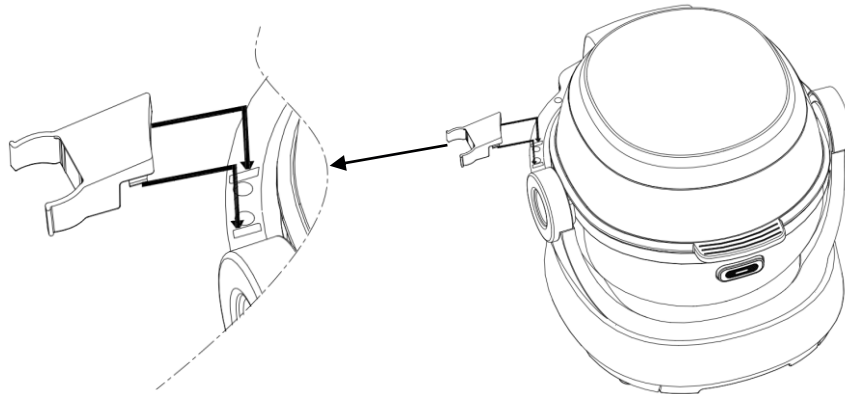

2. After the handle holder is fixed, you can place the handle on it when not in use. As shown in Figure 1: Insert the handle into the notch of the handle bracket. As shown in Figure 2: Pull the handle to the right to take it out when you need to use it

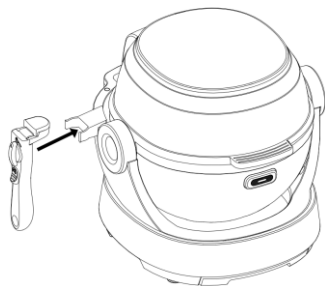

Fig1

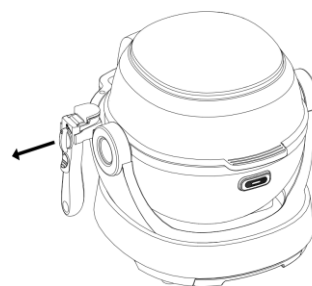
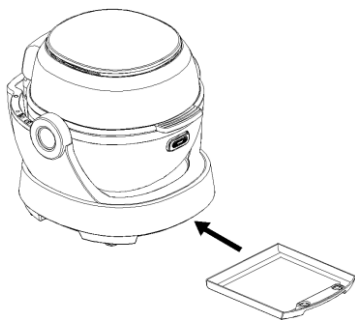

Fig2

Installation of the Oil Tray

After taking the Oil Tray out of the foam, insert the rear end of the Oil Tray into the gap at the bottom of the machine as shown in the picture. When it is fully inserted, the Oil Tray will be automatically fixed in the machine..



Specification

Voltage	220V~240V
Power	1700W
Frequency	50-60Hz
Temperature Range	40-250°C
Time setting Range	1min-2hours (Below 230°C) 1min-30mins (Above 230°C) 1hour -24hours (Dehydrate)
Capacity	6L

Control panel

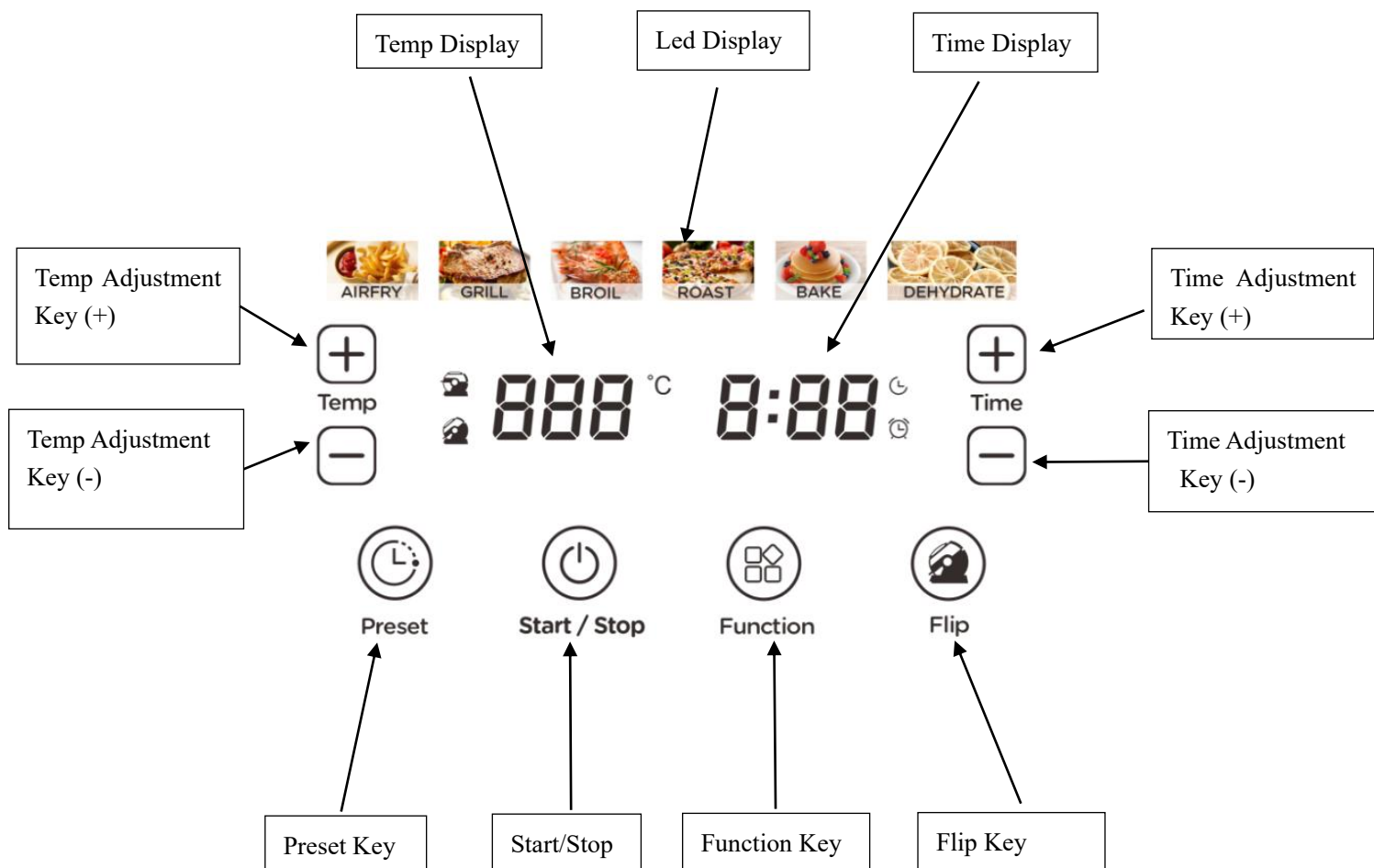

Parameter reference table for difference modes

Mode	Default Temp (°C)	Default Time	Suggested accessories
GRILL	230	10mins	/
AIR FRY	250	20mins	/
BROIL	250	10mins	/
ROAST	180	25mins	Low rack
BAKE	160	25mins	Low rack
DEHYDRATE	70	6hours	Low rack

Note: It is recommended that the total weight of food should not exceed 2.5kg.

Basic procedures

1. Press the lid release button to open the lid. Pull up it to the designated angle by holding the lid handle. Below is the correct method of opening or closing the lid of the appliance:



2. Put in the cooking pot and the accessories (if required) and the food to be cooked.
Note: Do not stack the food close to the heating element or the food may get charred.
3. The machine will automatically reset to its home position after being powered on. Press the Start key once, and the product enters stand-by mode. six zeros (000000) will be shown on the LED display
4. Press the Function key to select appropriate mode, the corresponding default time and temperature will be shown on the LED display screen. The time and temperature may be set to the individual need.
5. If no mode setting is assigned, the product still can operate if the time and temperature setting is made. Time and temperature can be adjusted by pressing +/- button. Press Time adjustment key to



adjust time, every change is 1min as an unit. Press Temp. adjustment key to adjust temperature, every change is 10°C as an unit.

EXCEPT FOR Dehydrate function. Dehydrate function very change is 5°C as an unit.

Time and temperature can be quickly increased or decreased by pressing time and temperature adjustment key touch & hold.

Press Start/Stop Button, the machine will start to work after finished adjusting time and temperature that needed.

6. The tilt function can be selected as needed: After choosing the desired function, press the "Flip"

key  once. The tilt icon  on the screen will light up, indicating that the machine will automatically

tilt during operation. During the tilting process, press the "Flip" key  again, and the machine will enter

a hovering state. When the machine is in the hovering state, double-click the "Flip" key , and the machine will tilt in the opposite direction.

Note: Refer to below recipe table to choose the correct cooking direction.

7. After setting the function, confirm the tilt function selection and press the Start key to initiate operation. The machine will then tilt forward automatically, and the cooking pot keeps rotating throughout the cooking process. Unique tilt function and pots continuously turn ingredients for even browning.

8. When a certain temperature is reached, the heating element may pause. The heating element will restart after the temperature has dropped. The process repeats until the set time is reached

9. If additional food needs to be added during the cooking process when the machine is in an inclined

position, press the "flip key"  to place the machine at vertical direction. Then, pull up the lid after pressing the lid release button, the product will stop heating immediately. Close the lid after the food is

added and the process will continue. Press the "flip key"  again. The machine will then tilt forward automatically.

Warning: The lid cannot be opened when the machine is at tilt direction.

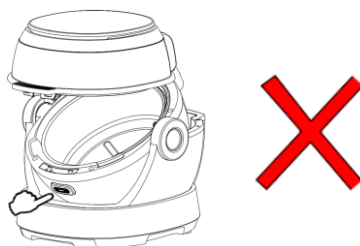

10. When the set time is reached, the product will give an indicating sound. Once cooking is complete, the machine will return to the vertical position automatically. Remove the plug and take out the food. Handle the hot items with care to avoid scald. Place the pot on an insulating pad to avoid causing damage to the table top.

11. In the standby mode, press PRESET key, then set the appointment time through timer key. The default setting is 30 minutes. Each click is minute difference with 1 minute. The time range is from 1 minute to 9 hours and 59 minutes. When the time is up to 1 hour, time will be changed in 30 mins as an unit by pressing temperature adjustment key touch and hold. Press the “Start” key after setting the preset time. And then press the “Function” Key to select appropriate mode. You can also press the temp/ time (+)(-)key to set the temperature and the time. Then press “start” key to confirm the preset function, the cooking time will count down. The alarm icon  will be displayed on the LED display screen during the preset time countdown.

12. Fig.1 is oil plug① use for sealing oil, if need to exhaust the food excess grease out of machine, please pull out oil plug as fig.2, then start cooking, by this way, the food oil and grease can exhaust from the holes in the cooking pot side. But this only can be used at tilt direction. If need to put the oil plug back to the cooking pot, just put the oil plug small side ② align to the cooking pot hole and insert as fig.3.

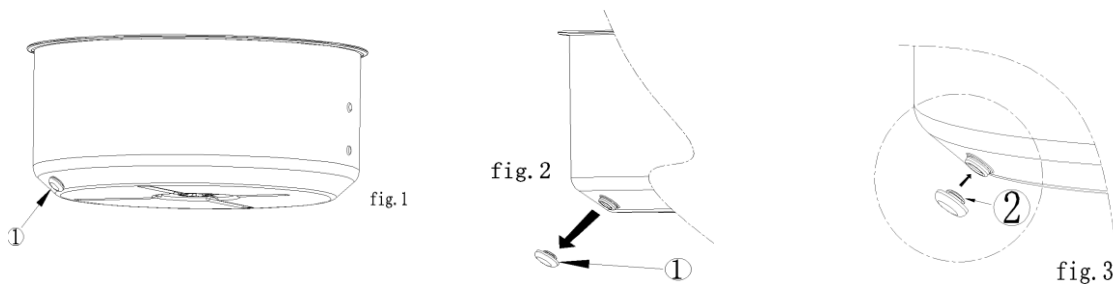

13. There are 2 holes with oil plugs at the Oil receiver, in case of missing the oil plugs. Just pull out the oil plugs when use.

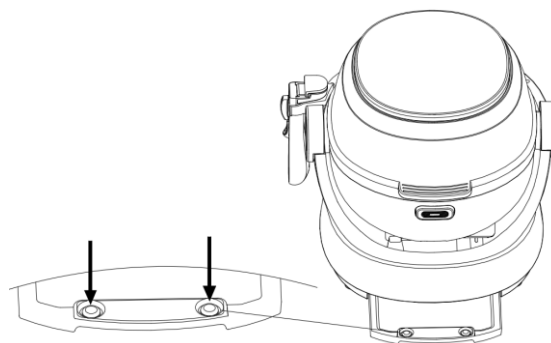

(1)During cooking, if the food water is more, there will have small amount of water expel from the cooking pot and may have drops on the Transparent Cover. This will not effect normal use, it is usual.

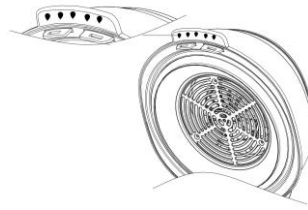

Basic Accessories

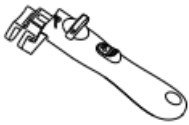

Handle

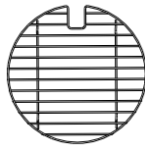

Low rack



Oil receiver

Item	Description
Handle	A handy tool for carrying pots
Low rack	Be used for baking or roasting
Oil receiver	To load the oil and grease

Optional Accessories

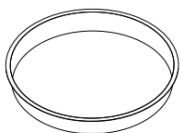

Baking Pan

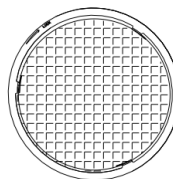

Filter

Item	Description
Baking Pan	Be used with the low rack for baking
Filter	Use the filter to be fixed onto the heater shield, to prevent the accumulation of grease inside the heater

How to use the accessories

- **Pot handle**

1. Pull back button ①, the buckle ② will flick automatically as fig.1
2. Put the handle at the notch of the base as fig.1
3. Then anticlockwise twist rotary knob ③, buckle ② will frap and clamp the cooking pot, then lift up the cooking pot as fig.1.
4. If want to take away pot handle, repeat the action of step 1-- Pull back button ①, the buckle ② will flick automatically, then take out the handle as fig.2

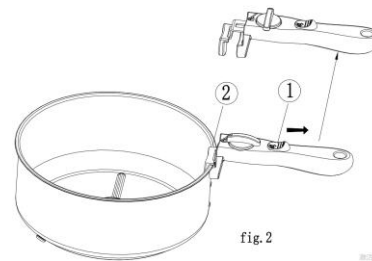
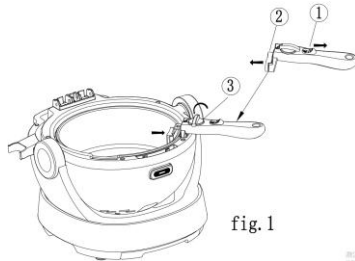

- **Low rack**

Put the rack into the cooking pot. Place the food on the rack direct, choose the desired functions.

- **Oil receiver**

Use to load food oil and grease, when need to pour out the oil and grease, pull out the oil receiver from the front. After clean, push in the oil receiver back to the base.

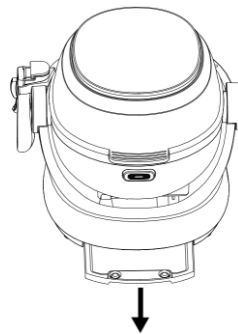

- **Baking pan and tong**

1. Place the low rack into the cooking pot, put the baking pan onto the rack, place the food inside and choose the desired function.
2. Press "START".

Remark: The tong is helpful to move the accessories and food.

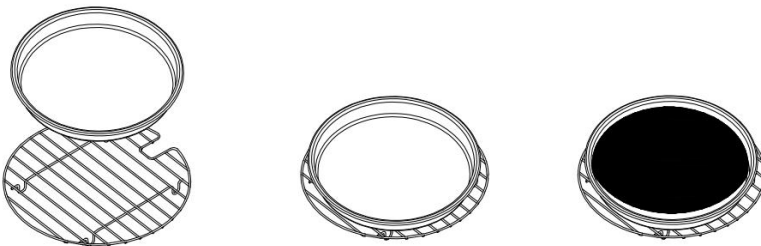





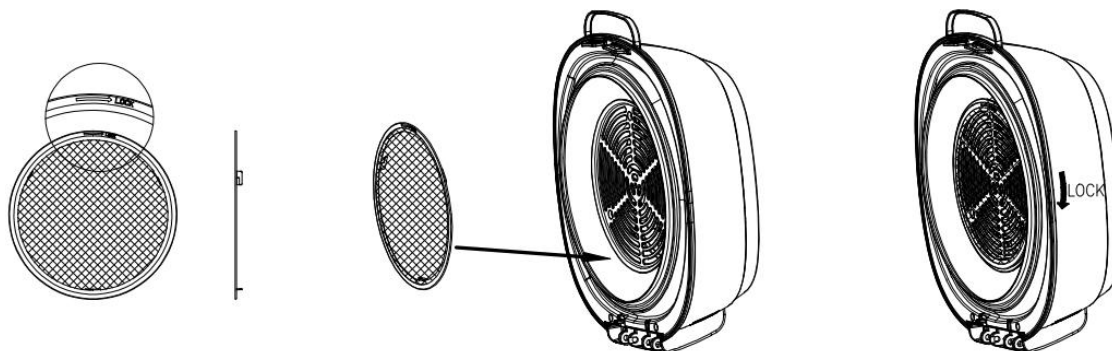









- **Filter**





1. Before cooking any food which contains fats, it is recommended to use the stainless steel grease filter to be fixed onto the heater shield, to prevent the accumulation of grease inside the heater.
2. Place the filter under the heater shield, rotate clockwise.
Clean and dry the stainless steel filter after every cooking.



Cooking table

The cooking times are a guide only. They could vary depending on quantity, temperature and weight etc.

Food	Temperature	Cooking time	Cooking direction	Recommended accessories
Drumstick	250°C	15~20 mins		Cook in the pot directly
Steak	200°C	8~12 mins		Low rack
Fish	200°C	10~15 mins		Low rack
Egg	200°C	8~12 mins		Low rack
Chicken	200°C	35~45 mins	 	Cook in the pot directly or with low rack
Breads	200°C	10~15 mins		Low rack
Small cakes	160°C	20~25 mins		Low rack
pizza	220°C	8~12 mins		Low rack
Dried fruit/Vegetables	70°C	7hrs		Low rack
French Fries	250°C	15~20 mins		Cook in the pot directly
Chicken Nuggets	210°C	10~15 mins		Cook in the pot directly
Mushrooms	230°C	10~12 mins		Cook in the pot directly
Brussels Sprouts	200°C	20~25 mins		Cook in the pot directly
Coffee Bean	250°C	15~25 mins		Cook in the pot directly

Nuts	180°C	8~10 mins		Cook in the pot directly
Sausages	220°C	8~12 mins		Cook in the pot directly
Potatoes	250°C	20~25mins		Cook in the pot directly
Shrimps	200°C	10-12mins		Cook in the pot directly

How to clean

Please let the body cool down before cleaning to prevent scald.

- Please remove the plug from the power outlet before cleaning
- The housing of the machine can be cleaned with a mildly damp cloth
- Inner pot and accessories like tong, Baking Pan, Low rack. Filter can be washed and cleaned water with mild detergent
- Do not immerse the machine in water

Please make sure the accessories are dry before using it again.